



EARTH LEAKAGE RELAY I-AB

A01044B

Operation Manual

Product name: **I-AB Earth Leakage Relay Manual**
Part number: A01044B

Version: 1.0
Date: June 2010

Copyrights

All rights reserved. This document may not, in whole or part, be copied, photocopied, reproduced, translated, or reduced to any electronic medium or machine readable form without the express written permission of Bramco Electronics.

Disclaimer

Bramco electronics has made every attempt to ensure that the information contained in this document is accurate and complete. Bramco electronics makes no representation or warranties of merchantability or fitness for any particular purpose. Bramco Electronics reserves the right to make changes to the system and/or document at any time without notice.

Bramco Electronics

Unit 2&3 Callistemon Close,
Warabrook NSW 2304
Australia
www.bramco.com.au

Ph: +61 2 4014 4444
Fax: +61 2 4967 4100
Email: sales@bramco.com.au

Index

OVERVIEW	4
1. FEATURES	4
1.1. PHYSICAL LAYOUT	4
1.2. TERMINAL CONNECTIONS	5
1.3. BASIC ENCLOSURE DIMENSIONS	6
2. OPERATION	7
2.1. OUTLINE	7
2.2. FAILSAFE/NON-FAILSAFE MODE	7
2.3. LATCHING/NON-LATCHING MODES	8
2.4. REMOTE RESET	8
2.5. TOROID OPEN	8
2.6. TRIP PARAMETERS	8
3. SPECIFICATIONS	9
4. INSTALLATION	10
4.1. GENERAL RECOMMENDATIONS	10
4.2. I-AB RELAY	10
4.3. I-AB OPERATING VOLTAGE	11
4.4. EL TOROIDS	11
5. FAULT DIAGNOSIS	12
6. TYPICAL CONNECTIONS	13

Overview

The Bramco IA/B Earth Leakage relay has been designed to detect Earth current faults flowing in a power system and to provide visual indication of Earth Leakage conditions.

This relay is specifically designed to protect systems supplying VF Drives and provides very high immunity to converter noise.

1. Features

- Easily configured latch/non-latch and fail safe/non-fail safe mode of operation
- Toroid open protection and indication
- Adjustable trip current and delay time from front panel
- Front panel/relay latch reset button with rear panel disabling ability
- Provision for a remote reset button
- Existing trip condition cannot be over-ridden by reset function

Optional:

- Current loop or voltage output 4-20mA or 2-10V output available

1.1. Physical Layout

The IA/B relay is designed for Din rail or 2 hole, foot mounting.

- See Section 3 for Specifications and important power supply information.
- See Section 4 for Installation Recommendations.

1.2. Terminal Connections

Terminal Number	Description
1	110VAC CONTROL INPUT
2	110VAC CONTROL INPUT
3	COM 1
4	N/C 1
5	N/O 1
6	COM 2
7	N/O 2
8	N/C 2
9	EL TOROID (SCREEN TO 16)
10	EL TOROID (SCREEN TO 16)
11	NO CONN
12	4 – 20mA Pos OUTPUT
13	mA/V Neg OUTPUT
14	VOLTS POS 2-10V (LINK TO 12)
15	LATCH RESET
16	LATCH RESET , EARTH, SCREENS

1.3. Basic Enclosure Dimensions

I-AB Front View



I-AB Enclosure Dimensions

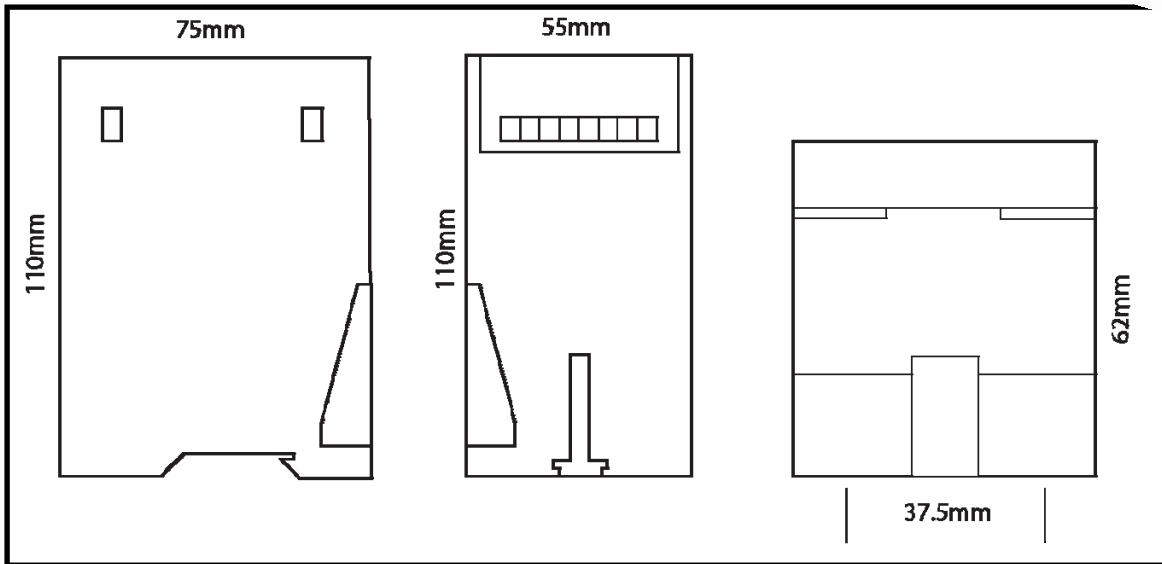

External Connections

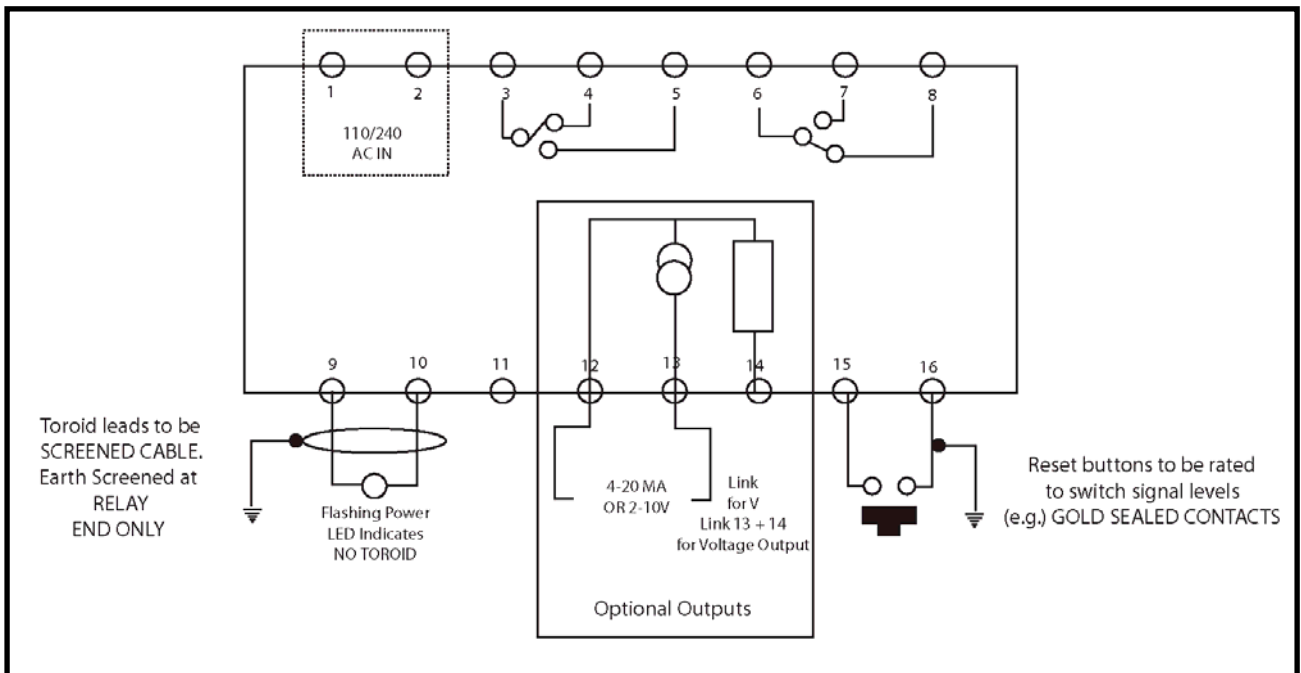

2. Operation

2.1. Outline

- Designed to provide EL protection on load circuits.
- Standard Bramco EL toroid. 500mA, (see factory for other values).
- Failsafe/Non-Failsafe operation.
- Latch/No Latch operation.
- EL Toroid open monitoring which flashes the Power Led.
- Adjustable Trip Current. 500mA
- Adjustable Trip Time. 500mS

Status Leds for –

- Power
- Warning
- Latched

NOTE: IA/B relay may be used on limited/unlimited neutral systems.

IA/B - C leakage external monitoring output:

- 4 – 20mA output into 250 ohms. Terminal 12 Positive, Terminal 13 Negative
- 2 -10V output is available by connecting Terminal 12 to 14 (Positive), Terminal 13 (Negative).

2.2. Failsafe/Non-Failsafe Mode

These modes are selected via the **FAILSAFE/NON-FAILSAFE** selector switch on the front of the unit.

NON-FAILSAFE - The IA/B relay is de-energised (open) when relay is un-powered and, energised (closed) with a fault.

FAILSAFE – The IA/B relay is de-energised (open) when relay is un-powered, and energised (closed) when the EL circuit is unlatched and healthy, and is de-energised (open) with an EL fault.

2.3. Latching/Non-Latching Modes

These modes are selected via the LATCH/NON-LATCH selector switch on the front of the unit.

Any EL trip in *Latch* mode causes the relay to latch the IA/B Relay contacts in the fault position.

When latched, a Remote or Local Reset is required to allow the IA/B relay contacts to return to the state before the fault.

2.4. Remote Reset

Remote Reset is achieved by connecting a N/O contact to terminals 15 and 16, and then closing that contact for more than 50ms.

The Remote Reset cannot over-ride a trip condition.

2.5. Toroid Open

The IA/B relay has toroid open monitoring, which will trip the relay if the EL toroid is not connected across the terminals.

2.6. Trip Parameters

Adjustment of the earth leakage Trip Current and Trip Delay Time is by front panel, single turn knob adjustment.

3. Specifications

Supply Voltage	A01044 – 120V or 240V 50/60Hz 2VA NOTE: IA/B when shipped is set to 120VAC Optional 24 – 48VAC/DC 2VA NOTE: This low voltage AC/DC supply must be isolated from Earth
Trip Current Range	50 – 500mA AC - Adjustable See factory for other ranges.
Frequency Range	40 – 100Hz Sine waveform Fundamental
Trip Delay Range	30 – 500mS - Adjustable See factory for other ranges.
Earth Leakage Current Monitor mA Output Option: -C	4 – 20mA (F.S @ 500mA AC) into 250 ohms maximum. 2 – 10V available by linking terminal 12 to 14. NOTE: Do NOT Earth Pos or Neg.
Relay Function	Failsafe or Non-Failsafe. (Switch selection) Latching or Non-Latching. (Switch selection)
Latch Reset	Remote: Typical 50mS contact closure required.
EL 2 Contact ratings	2 x C/O 5A 250VAC, 100VA max 5A 30VDC Resistive 3A 30VDC Inductive load 90W L/R 7mS
Maximum Switching Voltage	380VAC/125VDC

4. Installation

4.1. General Recommendations

Following are some recommendations for installation and wiring to help achieve successful operation.

4.2. I-AB Relay

The IA/B relay is supplied in a 16 terminal poly style enclosure with provision for Din rail or foot mounting.

IA/B relay and EL Toroid should be mounted away from stray flux sources such as power supplies, transformers, control relays and contactors and cables carrying load currents.

Use 2 core screened cable for the following inputs,

- EL Toroid,
- EL Remote LATCH RESET,
(voltage free contact)

Each individual cable screen should be connected to the IA/B relay to *Terminal 16*.

DO NOT earth the non-relay end of these screened cables.

It is recommended that these 2 screened cables are run by a direct route to the IA/B relay, **BUT**, are not to run with, or in cable harness or ducting with control or power cabling.

Where necessary, cross other cables at 90 degrees and provide maximum clearance from high voltage/current circuits as much as practically possible.

4.3. I-AB Operating Voltage

Either 120VAC or 240VAC or 110 - 240VAC or 24 – 48vDC input is connected to Terminals 1 and 2.

Before powering the IA/B, check the supply voltage matches the IA/B control voltage.

NOTE: If powered from 240VAC with the relay supplied as 120V, the IA/B will be damaged.

For 24 – 48VAC/DC, input is connected to terminals 1 (Pos) and 2 (Neg).

4.4. EL Toroids

IMPORTANT:

Match the EL Toroid Scaling with IA/B relay.

Use 500mA standard Bramco EL toroid with 500mA IA/B relay.

EL toroids have a powder coated mild steel, open faced enclosure, which acts as a shield to stray flux. For this to be effective the open side of the ELT should face away from stray flux sources such as transformers, relays and contactors, and for best effect, facing but not touching the steel enclosure body.

LOAD CABLE ORIENTATION

The three phase load power cables should be arranged to pass symmetrically through the centre of the EL toroid window.

5. Fault Diagnosis

To assist in fault diagnosis, a variety of typical faults are shown, with possible solutions given.

Indication	Possible condition/suggestion
Power Led is Off	- Check the module incoming supply voltage. AC or DC?
Power Led is On solid	- IA/B control relay will be open or closed dependant on Failsafe/Non Failsafe mode.
Power Led Flashing	- IA/B will have tripped, indicates EL Toroid is not connected.
Warning Led Off	- indicates earth leakage current is below 100%
Warning Led flicking On occasionally	- Indicates earth leakage is above the trip setting, is of a short duration, which does not exceed the trip delay commit time.
Tripped Led On solid	-
Latched Led On solid	-

6. Typical Connections

